

installation instructions

unitized washer/dryer 01

before you begin

Read these instructions completely and carefully.

important – Save these instructions for local electrical inspector's use.

important – Observe all governing codes and ordinances.

- Install the appliance according to the manufacturer's instructions and local codes.
- **note to installer** – Be sure to leave these instructions with the Consumer.
- **note to consumer** – Keep these instructions for future reference.
- Appliance installation must be performed by a qualified installer.
- This dryer **must** be exhausted to the outdoors.
- Before the old appliance is removed from service or discarded, remove the washer and dryer doors.
- Do not allow children on or in the appliance. Close supervision of children is necessary when the appliance is used near children.
- Proper installation is the responsibility of the installer.
- Product failure due to improper installation is not covered under the Warranty.
- Install the appliance where the temperature is above 50°F for satisfactory operation of the appliance control system.
- Remove and discard existing plastic or metal foil duct and replace with UL-listed duct.
- Service information and the wiring diagram are located at the access panel.

parts supplied



1 Cable Tie

2 Washer Hoses



2 Strainer Screens/
Rubber Washers



note: The Rubber Washers may be in the water hoses

warning - fire hazard

- Appliance installation must be performed by a qualified installer.
- Install the appliance according to these instructions and local codes.
- **do not** install a clothes dryer with flexible plastic venting materials. If flexible metal (semi-rigid or foil-type) duct is installed, it must be UL-listed and installed in accordance with the instructions found in "Connecting the Dryer to House Vent" later in this manual. Flexible venting materials are known to collapse, be easily crushed and trap lint. These conditions will obstruct dryer airflow and increase the risk of fire.
- **do not** install or store this appliance in any location where it could be exposed to water or weather.
- To reduce the risk of severe injury or death, follow all installation instructions.
- Save these instructions. (Installers: Be sure to leave these instructions with the customer.)

for gas dryers only

In the Commonwealth of Massachusetts, the following installation instructions apply:

- Installation must be performed by a qualified or licensed contractor, plumber, or gasfitter qualified or licensed by the State.
- If using a ball valve, it shall be a T-handle type.
- A flexible gas connector, when used, must not exceed 3 feet.



234D1335P016

installation instructions

unpacking your appliance

Tilt the appliance sideways and remove the foam shipping pads by pulling at the sides and breaking them away from the appliance legs. Be sure to remove all of the foam pieces around the legs.

After the machine is in the home, remove remaining packing material/carton from the appliance.

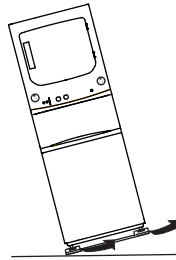

Remove the bag containing the washer hoses and parts from tub.

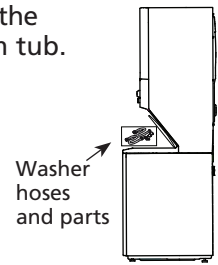

24" nominal product dimensions

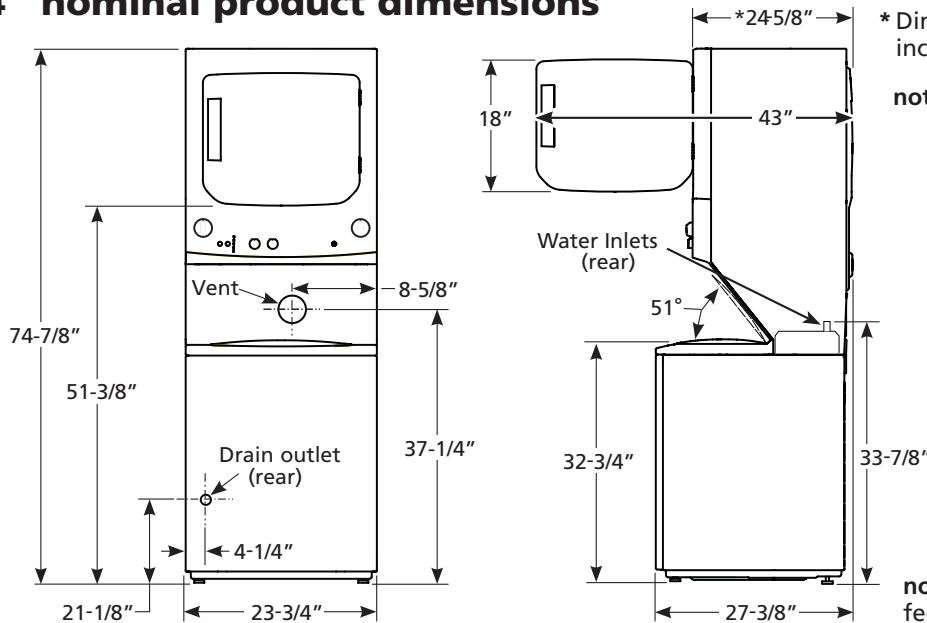

* Dimension represents door closed including handle and knobs.

note: All dimensions are within $\pm 1/8"$.

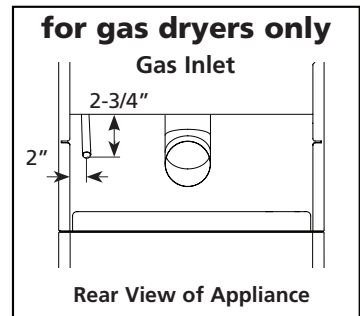

note: With feet set at mid position, feet can be adjusted $\pm 3/8"$.

27" nominal product dimensions

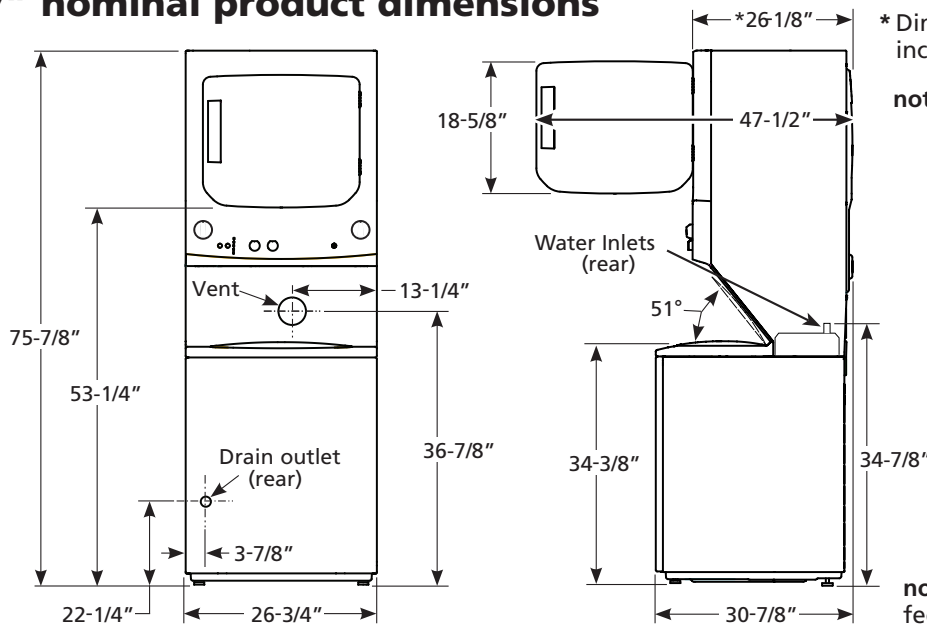

* Dimension represents door closed including handle and knobs.

note: All dimensions are within $\pm 1/8"$.

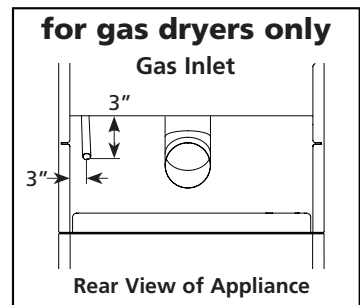

note: With feet set at mid position, feet can be adjusted $\pm 3/8"$.

installation instructions

requirements for alcove or closet installation

warning - **explosion hazard**

Keep flammable materials and vapors, such as gasoline, away from dryer.

Failure to do so can result in death, explosion, or fire.

- The dryer **MUST** be vented to the outdoors.
- Minimum clearance between dryer cabinet and adjacent walls or other surfaces is:
 - 0" either side
 - 0" rear
 - 1" front
 - 1" top
- Consideration must be given to provide adequate clearance for installation and service.
- Closet doors must be louvered or otherwise ventilated and doors must contain a minimum of:
 - 72 square inches of open area for GUD24 series models
 - 120 square inches of open area for GUD27 and GUV27 series models

note: WHEN THE EXHAUST DUCT IS LOCATED AT THE REAR OF THE DRYER, THE CONFIGURATION OF THE DUCTING MAY REQUIRE GREATER THAN 3" OF REAR CLEARANCE.

gas dryers only:

- No other fuel burning appliance shall be installed in the same closet as a gas dryer.
- The dryer must be disconnected from the gas supply piping during pressure testing at pressures greater than ½ psi (3.5 kPa).
- A 1/8 inch NPT minimum plugged tapping, accessible for test gauge connection, must be installed immediately upstream of the gas supply connection to the dryer.

minimum clearance other than alcove or closet installation

Minimum clearance to combustible surfaces and for air opening are: 0" both sides, 0" rear and 1" top. Consideration must be given to provide adequate clearance for installation and service.

installation requirements location

This appliance must be installed on firm flooring to minimize vibration during spin cycle. Concrete flooring is best, but wood base is sufficient, provided floor support meets FHA standards. This appliance should not be installed on rugs.

do not install the appliance:

1. In an area exposed to dripping water or outside weather conditions. Ambient temperature should never be below 60°F (15.6°C) for proper operation.
2. In an area where it will come in contact with curtains or drapes.
3. On carpet. The floor **MUST** be a hard surface with a maximum slope of 1/2" per foot (1.27 cm per 30 cm). To make sure the appliance does not vibrate or move, you may have to reinforce the floor.

note: If floor is in poor condition, use 3/4" impregnated plywood sheet solidly attached to existing floor covering.





mobile or manufactured home installation

- Installation **MUST** conform to the MANUFACTURED HOME CONSTRUCTION AND SAFETY STANDARD, TITLE 24, PART 3280 or STANDARD FOR MOBILE HOMES CAN/CSA-Z240 MH, or, when such standards are not applicable, with AMERICAN NATIONAL STANDARD FOR MOBILE HOME, ANSI/NFPA NO. 501B.
- The dryer **MUST** be vented to the outdoors.
- The exhaust vent **MUST** be securely fastened to a non-combustible portion of the mobile home.
- The vent **MUST NOT** be terminated beneath a mobile or manufactured home.
- The vent duct material **MUST BE METAL**.
- The vent **MUST NOT** be connected to any other duct, vent or chimney.
- **DO NOT** use sheet metal screws or other fastening devices which extend into the interior of the exhaust vent.
- Provide an opening with a free area of at least 25 square inches for introduction of outside air into the dryer room.
- See the sections for electrical connection information.



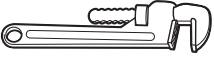







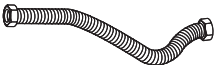

installation instructions

connecting a gas dryer (skip for electric dryers)

tools you will need

- 10" Adjustable wrenches (2)

- 8" Pipe wrench

- Slip-joint pliers

- Flat-blade screwdriver

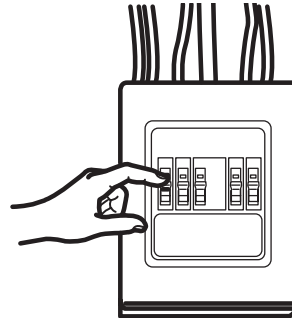
- 1/4" Nutdriver

- Level

materials you will need

- 4" dia. metal elbow

- Pipe compound or PTFE tape

- Flexible gas line connector

- Duct clamps (2) or Spring clamps (2)

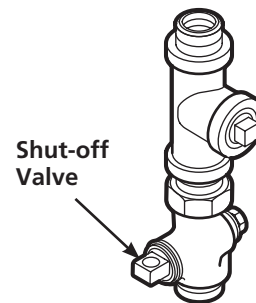
- Safety glasses

- 4" dia. metal duct (recommended)

- 4" dia., UL-listed flexible metal duct (if needed)

- Gloves

- Soap solution for leak detection

- Exhaust hood

- Duct tape

- Gas pipe adapters (2) (for 27" dryers only), elbow (for 27" dryers only) and pipe plug

- Before beginning the installation, turn off the circuit breaker(s) or remove the dryer's circuit fuse(s) at the electrical box. Be sure the dryer cord is unplugged from the wall.



- Turn the dryer's gas shut-off valve in the supply line to the OFF position.



- Disconnect and discard old flexible gas connector and ducting material.



installation instructions

gas requirements

⚠ warning - explosion hazard

- Use a new CSA International approved flexible gas supply line. Never reuse old flexible connectors.
 - Install an individual manual shut-off valve within 6ft. of the dryer in accordance with the National Fuel Gas Code, ANSI Z223.1/NFPA 54.
 - Securely tighten all gas connections.
 - If connected to LP gas, have a qualified person make sure gas pressure **DOES NOT** exceed 13" water column.
 - Examples of a qualified person include: licensed heating personnel, authorized gas company personnel, and authorized service personnel.
 - Failure to do so can result in death, explosion, or fire.
- The installation must conform with local codes, or in the absence of local codes, with the National Fuel Gas Code, ANSI Z223.1/ NFPA 54, or the Natural Gas and Propane Installation Code, CSA B149.1.

dryer gas supply connection

You must use with this dryer a flexible metal connector (listed connector ANSI Z21.24 / CSA 6.10). The length of the connect shall not exceed 3 ft.

gas supply

- A 1/8" National Pipe Taper thread plugged tapping, accessible for test gauge connection, must be installed immediately upstream of the gas supply connection to the dryer. Contact your local gas utility should you have questions on the installation of the plugged tapping.
- Supply line is to be 1/2" rigid pipe and equipped with an accessible shutoff within 6 feet of, and in the same room with, the dryer.
- Use pipe thread compound appropriate for natural or LP gas or use PTFE tape.
- Connect flexible metal connector to dryer and gas supply.

⚠ warning - fire hazard

for use with natural gas only

Dryer as produced by manufacturer is to be used only with a natural gas supply. A manufacturer-supplied conversion kit is required to convert this dryer for propane gas supply.

Conversion must be made by properly trained and qualified personnel in accordance with local codes and ordinances.

adjusting for elevation

- Gas clothes dryers input ratings are based on sea level operation and need not be adjusted for operation at or below 2000 ft. elevation. For operation at elevations above 2000 ft., input ratings should be reduced at a rate of 4 percent for each 1000 ft. above sea level.
- Installation must conform to local codes and ordinances or, in their absence, the NATIONAL FUEL GAS CODE, ANSI Z223.

installation instructions

connecting a gas dryer (cont.)

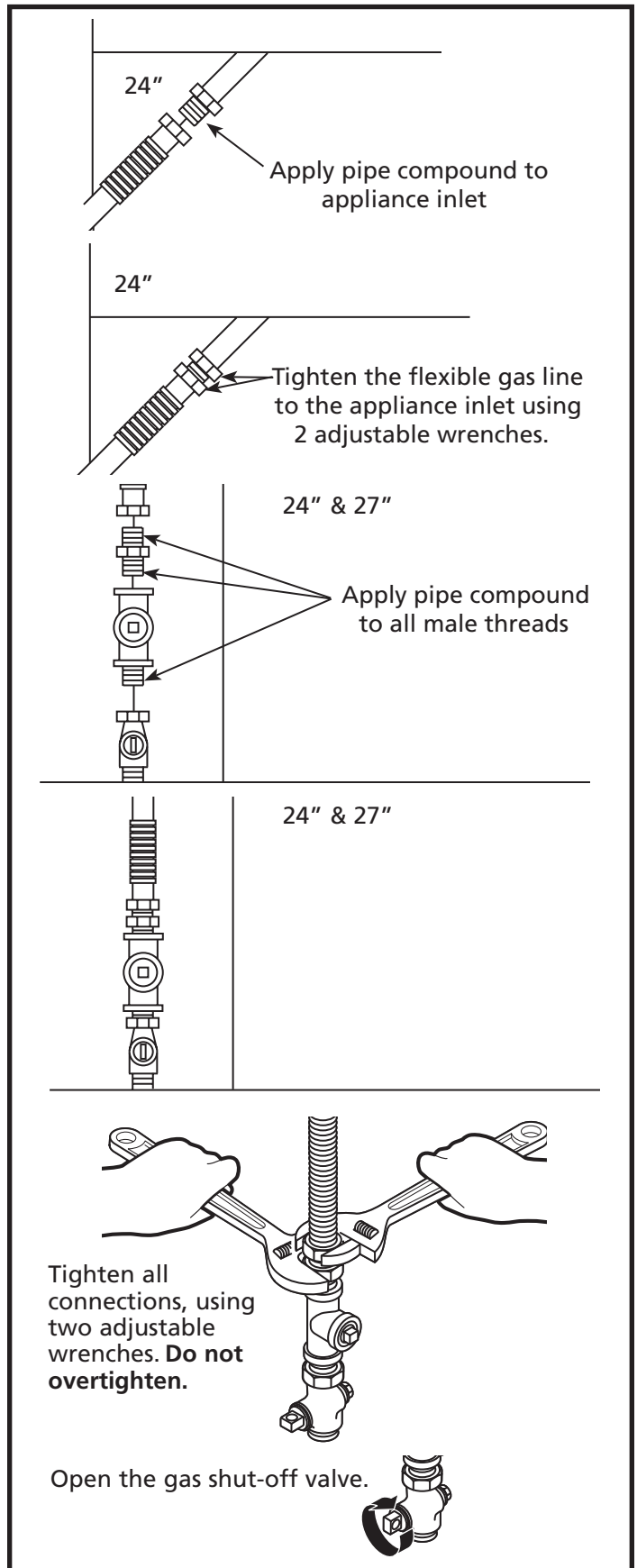
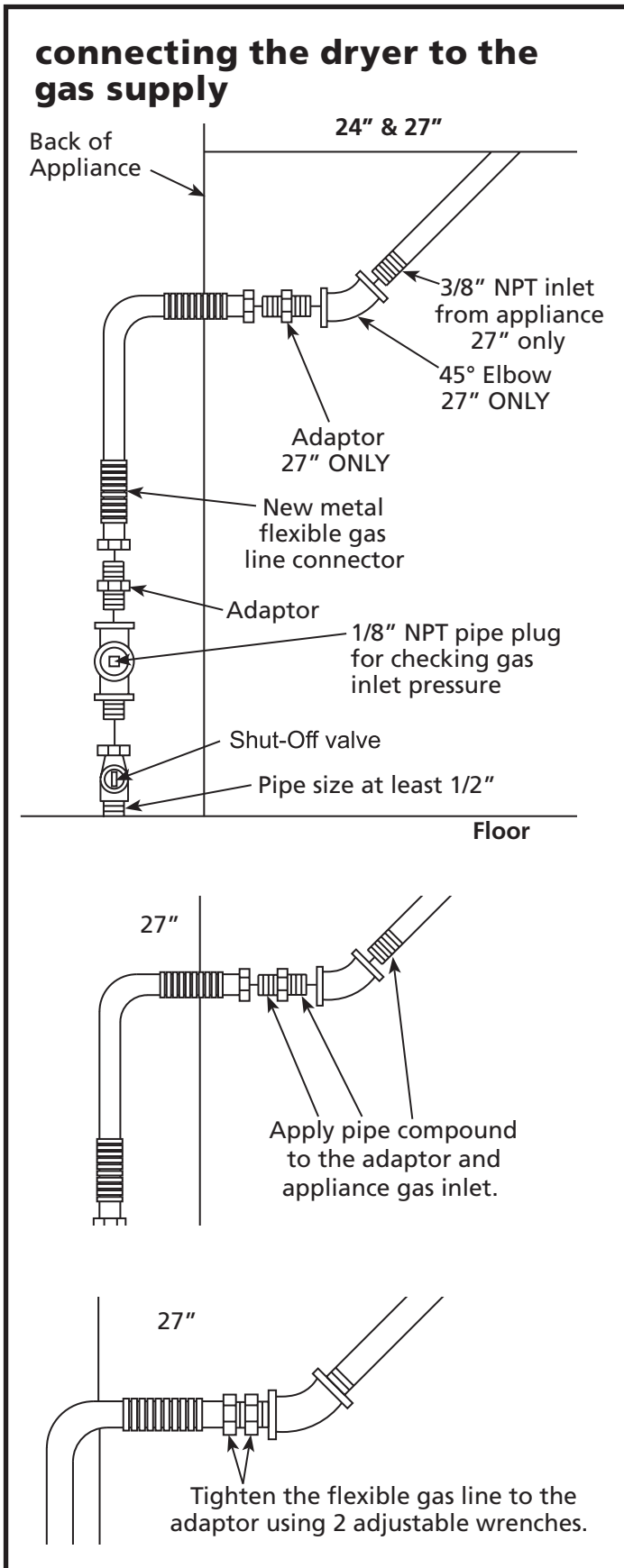

installation instructions

test for leaks

never use an open flame to test for gas leaks.

Check all connections for leaks with soapy solution or equivalent.

Apply a soap solution. The leak test solution must not contain ammonia, which could cause damage to the brass fittings.

If leaks are found, close the valve, retighten the joint and repeat the soap test.

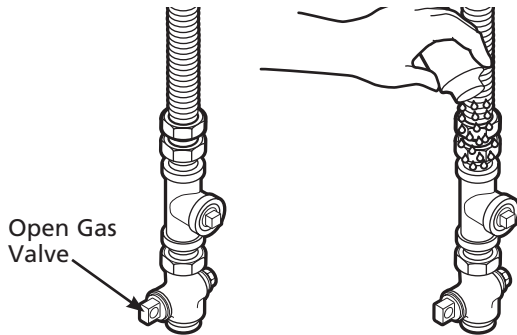

electrical connection information for gas dryers

⚠ warning - electrical shock hazard

Plug into a grounded 3 prong outlet.

do not remove ground prong.

do not use an adapter.

do not use an extension cord.

Failure to do so can result in death, fire or electrical shock.

- **Circuit** – Individual properly polarized and grounded 15 or 20 amp circuit breaker or time-delay fuse.

- **Power Supply** – 2-wire plus ground, 120 Volt, single phase, 60 Hz, alternating current.

- **Outlet Receptacle** – Properly grounded 3-prong receptacle to be located so the power cord is accessible when the dryer is in an installed position. If a 2-prong receptacle is present, it is the owner's responsibility to have a licensed electrician replace it with a properly grounded 3-prong grounding type receptacle.

Ensure proper ground exists before use.

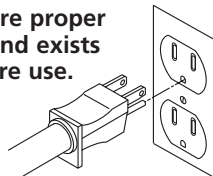

electrical connection information for gas dryers (cont.)

- Appliance must be electrically grounded in accordance with local codes and ordinances, or in the absence of local codes, with the latest edition of the NATIONAL ELECTRICAL CODE, ANSI/NFPA NO. 70 or CANADIAN ELECTRICAL CODE, CSA C22.1. Check with a licensed electrician if you are not sure that the dryer is properly grounded.

grounding instructions

This appliance must be grounded. In the event of a malfunction or breakdown, grounding will reduce the risk of electric shock by providing a path of least resistance for electric current. This appliance uses a cord having an equipment-grounding conductor and a grounding plug. The plug must be plugged into an appropriate outlet that is properly installed and grounded in accordance with all local codes and ordinances.

⚠ warning Improper connection of the equipment-grounding conductor can result in a risk of electric shock. Check with a qualified electrician, or service representative or personnel, if you are in doubt as to whether the appliance is properly grounded. cord. **do not** modify the plug on the power supply. If it will not fit the outlet, have a proper outlet installed by a qualified electrician.





save these instructions

installation instructions









connecting an electric dryer

(skip for gas dryers and if your dryer already has a power cord attached)

tools you will need

- Slip-joint pliers 
- Flat-blade screwdriver 
- Phillips screwdriver 
- 1/4" Nutdriver 
- Level 

materials you will need

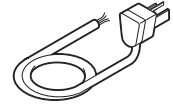
- 4" dia. metal elbow 
 - 3/4" Strain relief (UL recognized) 
 - 4" Duct clamps (2) or 4" spring clamps (2) 
 - Safety glasses 
 - 4" dia. metal duct (recommended) 
 - 4" dia., UL-listed flexible metal duct (if needed) 
 - Gloves 
 - Exhaust hood 
 - Duct tape 
 - Appliance power cord kit (not provided with appliance) 
- UL rated 120/240V, 30A with 3 or 4 prongs. Identify the plug type as per the house receptacle before purchasing line cord.

Before making the electrical connection, turn off the circuit breaker(s) or remove the dryer's circuit fuse(s) at the electrical box. Be sure the dryer cord is unplugged from the wall. **never leave the access cover off the terminal block.**

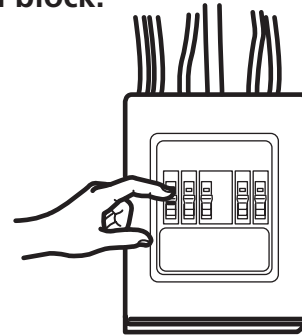

electrical connection location

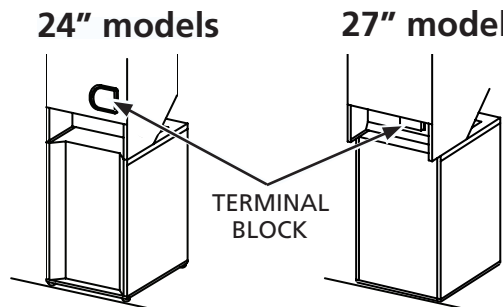

installation instructions

electrical connection information for electric dryers

for electrical connections using a power cord:

warning - fire hazard

Use a new UL-listed 240V 30 amp dryer power supply cord with closed ring terminals or spade terminals with upturned ends.

Use a UL-listed strain relief.

Disconnect power before making electrical connections.

Connect neutral wire (white or center wire) to center terminal.

Ground wire (green or bare wire) must be connected to green ground connector.

Connect remaining two supply wires to remaining two terminals.

Securely tighten all electrical connections.

Replace the terminal block cover.

Failure to do so can result in death, fire or electrical shock.

grounding instructions

For a grounded, cord-connected dryer: This appliance must be grounded. In the event of a malfunction or breakdown, grounding will reduce the risk of electric shock by providing a path of least resistance for electric current. This appliance uses a cord having an equipment-grounding conductor and a grounding plug. The plug must be plugged into an appropriate outlet that is properly installed and grounded in accordance with all local codes and ordinances.

 **warning** Improper connection of the equipment-grounding conductor can result in a risk of electric shock. Check with a qualified electrician, or service representative or personnel, if you are in doubt as to whether the appliance is properly grounded. **DO NOT** modify the plug on the power supply cord. If it will not fit the outlet, have a proper outlet installed by a qualified electrician.

save these instructions

electrical connection information for electric dryers

for direct wire connections:

warning - fire hazard

Use 10 gauge solid copper wire.

Use a UL-listed strain relief.

Disconnect power before making electrical connections.

Connect neutral wire (white or center wire) to center terminal.

Ground wire (green or bare wire) must be connected to green ground connector.

Connect remaining two supply wires to remaining two terminals.

Securely tighten all electrical connections.

Replace the terminal block cover.

Failure to do so can result in death, fire or electrical shock.

grounding instructions

For a permanently connected dryer: This appliance must be connected to a grounded metal, permanent wiring system, or an equipment-grounding conductor must be run with the circuit conductors and connected to the equipment-grounding terminal on the appliance.

 **warning** Improper connection of the equipment-grounding conductor can result in a risk of electric shock. Check with a qualified electrician, or service representative or personnel, if you are in doubt as to whether the appliance is properly grounded.

save these instructions

installation instructions

24" models - connecting an electric dryer

connecting dryer using 4-wire connection (must be used for mobile home installation)

note: Since January 1, 1996, the National Electrical Code requires that new constructions use a 4-wire connection to an electric dryer. A 4-wire cord must also be used where local codes do not permit grounding through the neutral.

3-wire connection is NOT for use on new construction.

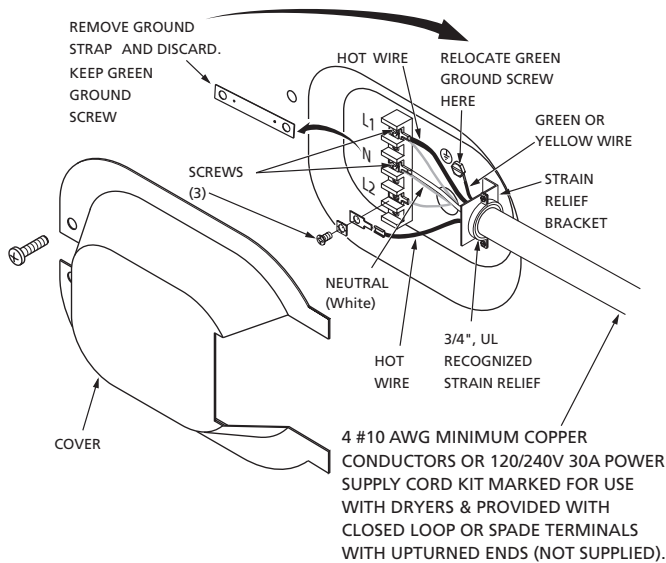

1. Turn off the circuit breaker(s) (30 amp) or remove the dryer's circuit fuse at the electrical box.
2. Be sure the dryer cord is unplugged from the wall receptacle.
3. Remove the power cord cover located at the lower back.
4. Remove and discard ground strap. Keep the green ground screw for Step 7.
5. Install 3/4 in. UL-recognized strain relief to power cord entry hole. Bring power cord through strain relief.
6. Connect power cord as follows:
 - A. Connect the 2 hot lines to the outer screws of the terminal block (marked L1 and L2).
 - B. Connect the neutral (white) line to the center of the terminal block (marked N).
7. Attach ground wire of power cord with the green ground screw (hole above strain relief bracket). Tighten all terminal block screws (3) securely.
8. Properly secure power cord to strain relief.
9. Reinstall the cover.

never leave the cover off of the terminal block.

connecting dryer using 3-wire connection

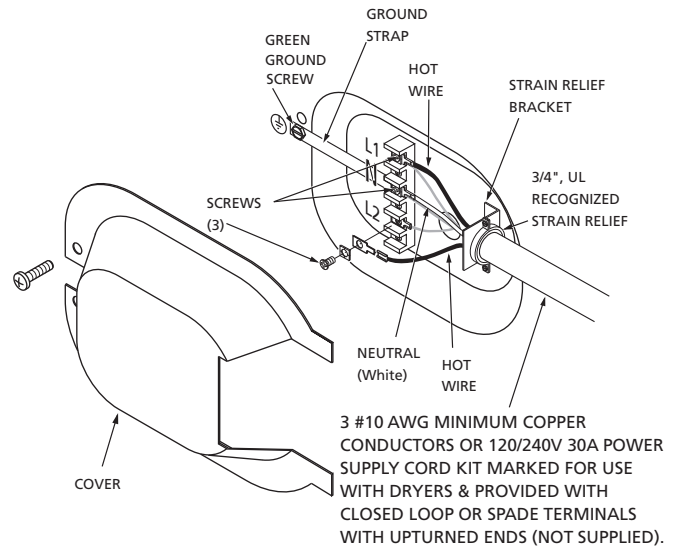

3-wire connection

not for use in Canada.

do not use for mobile home installations.

not for use on new construction.

not for use on recreational vehicles.

not for use in areas where local codes prohibit grounding through the neutral conduction.

1. Turn off the circuit breaker(s) (30 amp) or remove the dryer's circuit fuse at the electrical box.
2. Be sure the dryer cord is unplugged from the wall receptacle.
3. Remove the power cord cover located at the lower back.
4. Install 3/4-in. UL-recognized strain relief to power cord entry hole. Bring power cord through strain relief.
5. Connect power cord as follows:
 - A. Connect the 2 hot lines to the outer screws of the terminal block (marked L1 and L2).
 - B. Connect the neutral (white) line to the center of the terminal block (marked N).
6. Be sure ground strap is connected to neutral (center) terminal of block and to green ground screw on cabinet rear. Tighten all terminal block screws (3) securely.
7. Properly secure power cord to strain relief.
8. Reinstall the cover.

never leave the cover off of the terminal block.

installation instructions

27" models - connecting an electric dryer

connecting dryer using 4-wire connection (must be used for mobile home installation)

note: Since January 1, 1996, the National Electrical Code requires that new constructions use a 4-wire connection to an electric dryer. A 4-wire cord must also be used where local codes do not permit grounding through the neutral.

3-wire connection is NOT for use on new construction.

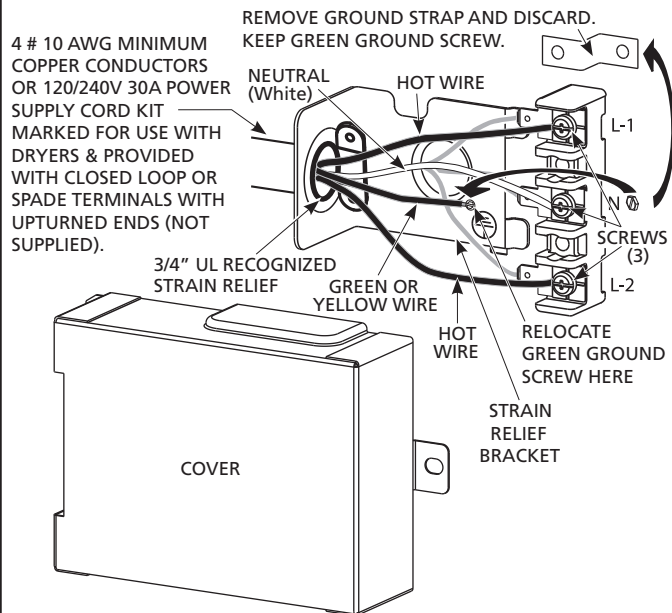

1. Turn off the circuit breaker(s) (30 amp) or remove the dryer's circuit fuse at the electrical box.
2. Be sure the dryer cord is unplugged from the wall receptacle.
3. Remove the power cord cover located on the back.
4. Remove and discard ground strap. Keep the green ground screw for Step 7.
5. Install 3/4 in. UL-recognized strain relief to power cord entry hole. Bring power cord through strain relief.
6. Connect power cord as follows:
 - A. Connect the 2 hot lines to the outer screws of the terminal block (marked L1 and L2).
 - B. Connect the neutral (white) line to the center of the terminal block (marked N).
7. Attach ground wire of power cord with the green ground screw (hole below strain relief bracket). Tighten all terminal block screws (3) securely.
8. Properly secure power cord to strain relief.
9. Reinstall the cover.

never leave the cover off of the terminal block.

connecting dryer using 3-wire connection

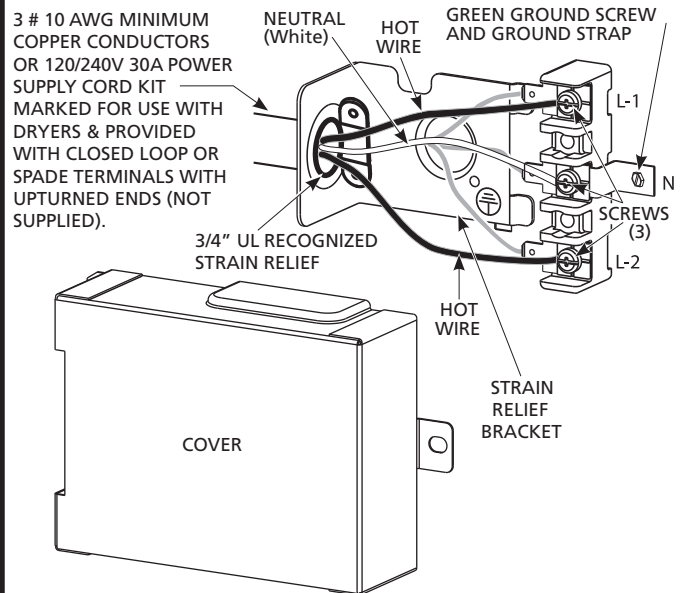

3-wire connection

not for use in Canada.

do not use for Mobile Home Installations.

not for use on new construction.

not for use on recreational vehicles.

not for use in areas where local codes prohibit grounding through the neutral conduction.

1. Turn off the circuit breaker(s) (30 amp) or remove the dryer's circuit fuse at the electrical box.
2. Be sure the dryer cord is unplugged from the wall receptacle.
3. Remove the power cord cover located on the back.
4. Install 3/4-in. UL-recognized strain relief to power cord entry hole. Bring power cord through strain relief.
5. Connect power cord as follows:
 - A. Connect the 2 hot lines to the outer screws of the terminal block (marked L1 and L2).
 - B. Connect the neutral (white) line to the center of the terminal block (marked N).
6. Be sure ground strap is connected to neutral (center) terminal of block and to green ground screw on cabinet rear. Tighten all terminal block screws (3) securely.
7. Properly secure power cord to strain relief.
8. Reinstall the cover.

never leave the cover off of the terminal block.

installation instructions

exhausting the dryer

⚠ warning - fire hazard

This dryer **MUST** be vented to the outdoors. Use only 4" rigid metal ducting for the home exhaust duct.

Use only 4" rigid metal or UL-listed dryer transition duct to connect the dryer to the home exhaust.

do not use a plastic vent.

do not exhaust into a chimney, kitchen exhaust, gas vent, wall, ceiling, attic, crawl space, or concealed space of a building.

do not install a screen in or over the exhaust duct.

do not install a booster fan in the exhaust duct.

do not use duct longer than specified in the exhaust length table.

Failure to follow these instructions can result in death or fire.

tools and materials you will need to install exhaust duct

Phillips-head screwdriver



Duct tape or duct clamp



Rigid or UL-listed flexible metal 4" (10.2 cm) duct

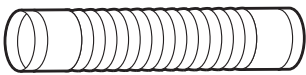

Drill with 1/8" drill bit (for bottom venting)

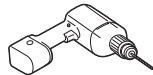

Hacksaw

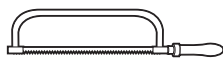

Vent hood



connecting the dryer to house vent

rigid metal transition duct

- For best drying performance, a rigid metal transition duct is recommended.
- Rigid metal transition ducts reduce the risk of crushing and kinking.

ul-listed flexible metal clothes dryer transition duct

- Never install transition duct in walls, ceilings, floors or other enclosed spaces.
- Total length of transition duct should not exceed 8' (2.4 m).
- For many applications, installing elbows at both the dryer and the wall is highly recommended (see illustrations in next section). Elbows allow the dryer to sit close to the wall without kinking and/or crushing the transition duct, maximizing drying performance.
- Avoid resting the duct on sharp objects.

ul-listed flexible metal (foil-type) transition duct

- In special installations, it may be necessary to connect the dryer to the home exhaust vent using flexible metal (foil-type) transition duct. UL-LISTED universal flexible dryer transition duct may be used **ONLY** in installations where rigid metal or flexible metal transition ducting cannot be used **AND** where a 4" diameter can be maintained throughout the entire length of the transition duct.
- In Canada and the United States, only transition ducts that comply with "**UL 2158A STANDARD FOR CLOTHES DRYER TRANSITION DUCT**" shall be used.
- Avoid resting the duct on sharp objects.
- For best drying performance:
 1. Slide one end of the duct over the clothes dryer outlet pipe.
 2. Secure the duct with a clamp.
 3. With the dryer in its permanent position, extend the duct to its full length. Allow 2" of duct to overlap the exhaust pipe. Cut off and remove excess duct. Keep the duct as straight as possible for maximum airflow.
 4. Secure the duct to the exhaust pipe with the other clamp.

installation instructions

exhausting the dryer (cont.)

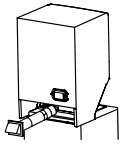

• **do** cut duct as short as possible and install straight into wall.

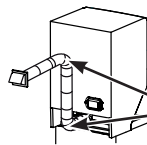

• **do** use elbows when turns are necessary.

Elbows

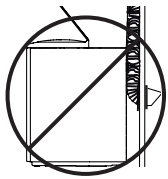

• **do not** bend or collapse ducting. Use elbows if turns are necessary.

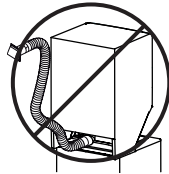

• **do not** use excessive exhaust length. Cut duct as short as possible.

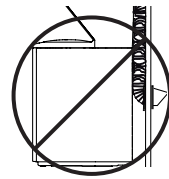

• **do not** crush duct against the wall.

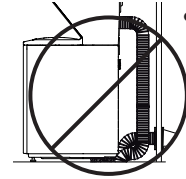

• **do not** set appliance on duct.

exhaust length

Using exhaust longer than specified length will:

- Increase the drying times and the energy cost.
- Reduce the dryer life.
- Accumulate lint, creating a potential fire hazard.

The correct exhaust installation is **your responsibility**.

problems due to incorrect installation are not covered by the warranty.

The **MAXIMUM ALLOWABLE** length of the exhaust system depends upon the type of duct, number of turns, the type of exhaust hood (wall cap) and all conditions noted on the chart.

- Internal elbows added for side or bottom vent conversions must be included in the total elbow count.
- Any elbow greater than 45° should be treated as a 90° elbow; one elbow of 45° or less may be ignored.
- Two 45° elbows will be treated like one 90° elbow. For the side exhaust installations, add one 90° elbow to the chart.
- For every additional 90° elbow, reduce the allowable vent system length by 10 feet.
- When calculating the total vent system length, you must add all the straight portions and elbows of the system (including the transition duct).

exhaust length 27" normal vent models

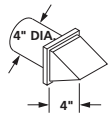
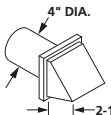
	recommended maximum length	
	Exhaust Hood Types	
	Recommended	Use only for short run installations
		
No. of 90° Elbows	Rigid Metal	Rigid Metal
0	56 Feet	42 Feet
1	48 Feet	34 Feet
2	40 Feet	26 Feet
3	32 Feet	18 Feet

exhaust length 27" long vent models

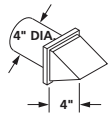
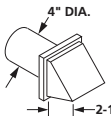
	recommended maximum length	
	Exhaust Hood Types	
	Recommended	Use only for short run installations
		
No. of 90° Elbows	Rigid Metal	Rigid Metal
0	200 Feet	175 Feet
1	185 Feet	165 Feet
2	175 Feet	155 Feet
3	165 Feet	145 Feet
4	155 Feet	135 Feet
5	145 Feet	125 Feet

exhaust length 24" normal vent models

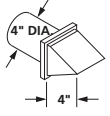
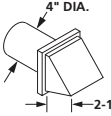
	recommended maximum length	
	Exhaust Hood Types	
	Recommended	Use only for short run installations
		
No. of 90° Elbows	Rigid Metal	Rigid Metal
0	43 Feet	36 Feet
1	33 Feet	26 Feet
2	24 Feet	16 Feet

installation instructions

exhausting the dryer (cont.)

exhaust system checklist

hood or wall cap

- Terminate in a manner to prevent back drafts or entry of birds or other wildlife.
- Termination should present minimal resistance to the exhaust airflow and should require little or no maintenance to prevent clogging.
- Wall caps must be installed at least 12" above ground level or any other obstruction with the opening pointed down.

separation of turns

- For best performance, separate all turns by at least 4 ft. of straight duct, including distance between last turn and dampened exhaust hood (wall cap).

sealing of joints

- All joints should be tight to avoid leaks. The male end of each section of duct must point away from the dryer.
- Duct joints should be made air- and moisture-tight by wrapping the overlapped joints with duct tape or aluminum tape.
- Do not assemble ductwork with any fasteners that extend into the duct. These fasteners can accumulate lint, creating a potential fire hazard.
- Horizontal runs should slope down towards the outdoors 1/4" per foot.
- Provide an access for inspection and cleaning of the exhaust system, especially at turns and joints. Exhaust system shall be inspected and cleaned at least once a year.

insulation

- Ductwork that runs through an unheated area or is near air conditioning should be insulated to reduce condensation and lint build-up.

before you begin

- Remove and discard existing plastic or metal foil duct and replace with UL-listed duct.
- Remove any lint from the wall exhaust opening.

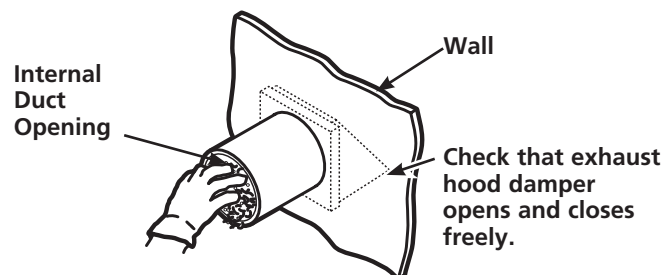

standard rear exhaust

This dryer comes ready for rear exhausting. If space is limited, use the instructions to exhaust directly from the sides or bottom of the cabinet.

Slide the end of the exhaust duct on the back of the dryer and secure with duct tape or a hose clamp.

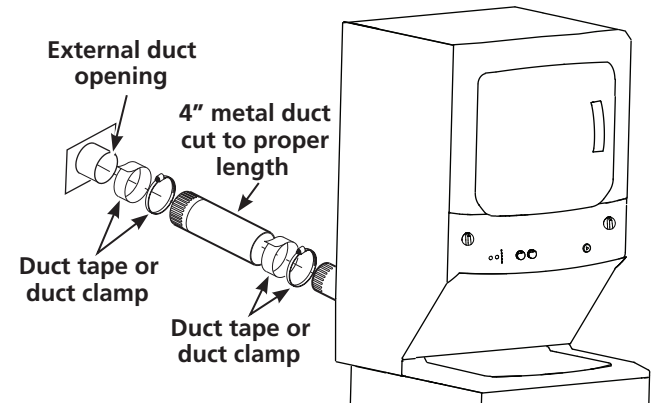

note: We strongly recommend using rigid metal exhaust duct. However, if flexible ducting is used it must be UL-Listed metal, not plastic.

- For straight line installation, connect the dryer exhaust to the external exhaust hood using duct tape or clamp.

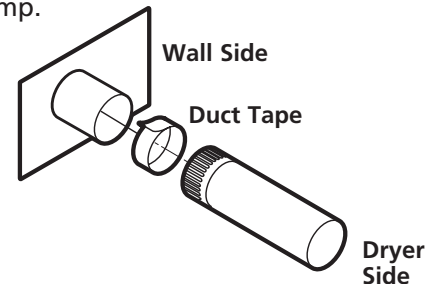

recommended configuration to minimize exhaust blockage

Using duct elbows will prevent duct kinking and collapsing.

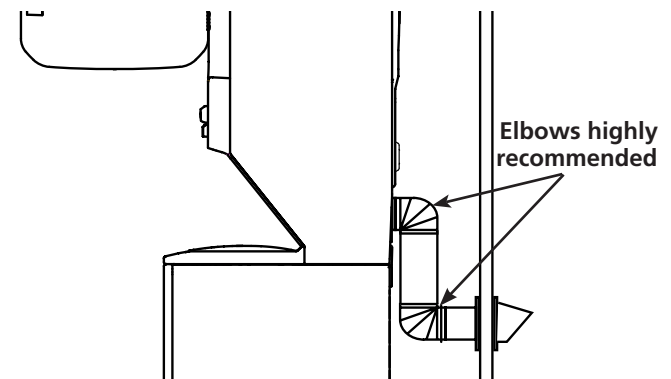

installation instructions

24" models only bottom or side venting

⚠ warning  - fire hazard

Disconnect dryer from electrical supply.

Wear gloves and arm guards.

Failure to do so may result in fire, electrical shock or lacerations.

for downward venting:

- Insert elbow, rotate it so that it points downward and connect it to the dryer's internal duct. Use only 4" UL approved rigid metal for ducting inside the dryer.

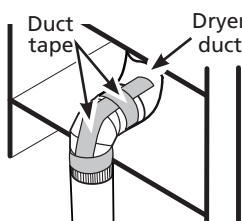

- Apply duct tape as shown on the joint between the dryer internal duct and the elbow, and also the joint between the elbow and the bottom duct.

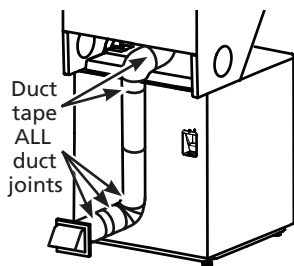

Internal duct joints must be secured with tape, otherwise they may separate and cause a safety hazard.

for side venting:

- Detach and remove the right or left side knockout (one only) as desired.
- Rotate elbow sections so that the opening points to the side to which you want to vent.
- Preassemble 4" elbow with 4" duct. Use only 4" UL approved rigid metal for ducting inside the dryer.
- Insert duct assembly through the side opening and connect to the internal dryer elbow duct.

Remove Desired Knockout (one only)

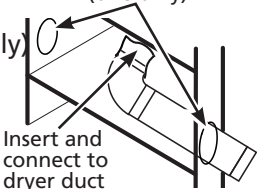

be sure not to pull or damage the electrical wires inside the dryer when inserting the duct.

- Apply duct tape as shown on the joint between the dryer internal duct and the elbow, and also the joint between the elbow and the side duct.

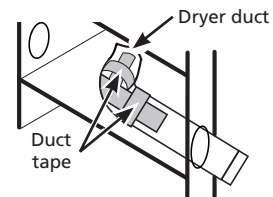

Internal duct joints must be secured with tape, otherwise they may separate and cause a safety hazard.

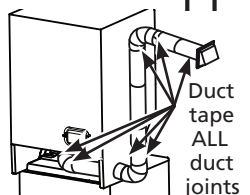

27" models only bottom or side venting

⚠ warning  - fire hazard

Disconnect dryer from electrical supply.

Wear gloves and arm guards.

Failure to do so may result in fire, electrical shock or lacerations.

for downward venting:

- Insert elbow, rotate it so that it points downward and connect it to the dryer's internal duct. Use only 4" UL approved rigid metal for ducting inside the dryer.

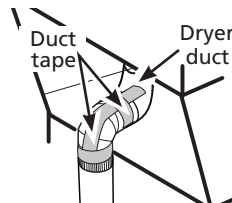

- Apply duct tape as shown on the joint between the dryer internal duct and the elbow, and also the joint between the elbow and the bottom duct.

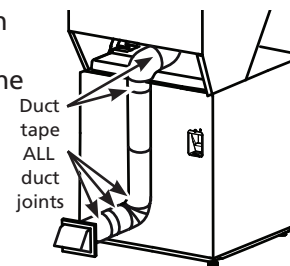

Internal duct joints must be secured with tape, otherwise they may separate and cause a safety hazard.

for side venting:

- Rotate elbow sections so that the opening points to the side to which you want to vent.
- Preassemble 4" elbow with 4" duct. Use only 4" UL approved rigid metal for ducting inside the dryer.
- Connect duct assembly to the internal dryer elbow duct.

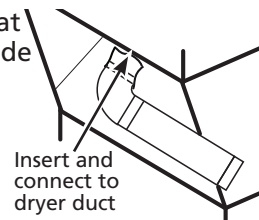

be sure not to pull or damage the electrical wires inside the dryer when inserting the duct.

- Apply duct tape as shown on the joint between the dryer internal duct and the elbow, and also the joint between the elbow and the side duct.

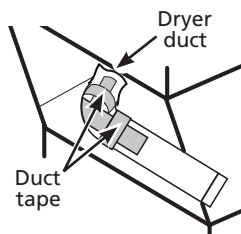

Internal duct joints must be secured with tape, otherwise they may separate and cause a safety hazard.

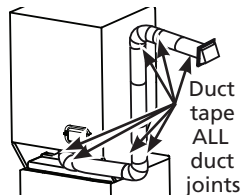

installation instructions

connecting the washer

plumbing information

water supply requirements

- **hot and cold water faucets** – Must be within 42" of the appliance water inlet hose connections. The faucets must be 3/4" garden hose-type so inlet hoses can be connected.
- **water pressure** – Must be between 20 and 120 pounds per square inch with a maximum unbalance pressure, hot vs. cold flowing, of 10 pounds per square inch.
- **water temperature** – Water heater should be set to deliver 120°F (50°C) to 150°F (66°C) in the washer when HOT wash is selected.
- **shut-off valves** – Both hot and cold water shut-off valves (faucets) should be supplied.
- **location** – Do not install appliance in an area where the temperature will fall below freezing. If appliance is stored or transported in freezing temperatures, be sure all water from the fill and drain systems has been removed.

drain requirements

- **drain rate** – The drain or standpipe must be capable of accepting a discharge at the rate of 16 gallons per minute.
- **drain height** – The drain height must be 30" minimum and 96" maximum.
- **standpipe diameter** – The standpipe diameter must be 1-1/2" minimum. There **MUST** be an air gap around the drain hose in the standpipe. A snug fit can cause a siphoning action.
- **siphon break** – For a drain facility less than 30" high, the hose, coupling and clamps provided in the machine must be used and, in addition, a siphon break **MUST** be installed on the back of the machine. Obtain and use a siphon break kit and follow the instructions in the kit.

connecting to plumbing facilities

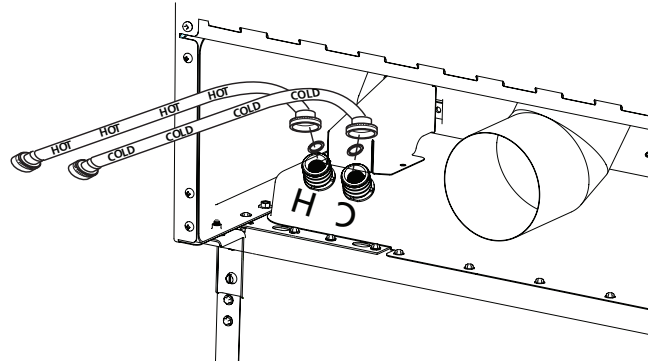

If not installed, install rubber washer in one end of hot water hose. Thread hot water hose onto connection labeled **H** at top rear of washer. Hand tighten, plus an additional 1/8 turn with pliers.

If not installed, install rubber washer in one end of cold water hose. Thread cold water hose onto connection labeled **C** at top rear of washer. Hand tighten, plus an additional 1/8 turn with pliers.

Move appliance as close to final location as possible, leaving room for you to make water, drain, electrical and vent connections to your home.

Insert free end of drain hose into drain opening of your home up to drain hose stopper (do not remove hose stopper it prevents siphoning). If water valves and drain are built into wall, fasten drain hose to one of water hoses with cable tie provided (ribbed side on inside). If your drain is a standpipe, fasten drain hose to standpipe with cable tie provided.

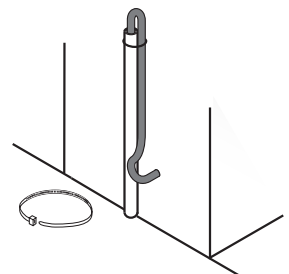
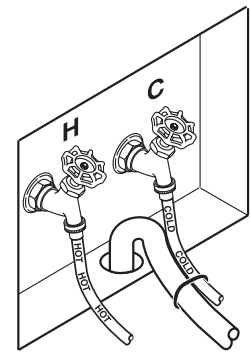

installation instructions

final setup

leveling and stabilizing your appliance

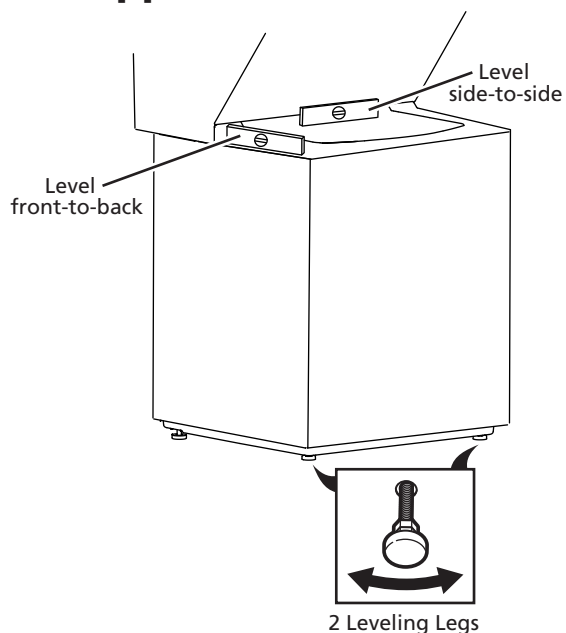

1. Carefully move the appliance to its final location. Gently rock the appliance into position. It is important not to damage the rubber leveling legs when moving your appliance to its final location. Damaged legs can increase appliance vibration. It may be helpful to spray window cleaner on the floor to help move your appliance to its final position.
note: Do not use washer cover to lift the unit.
2. To ensure the appliance is level and solid on all four legs, tilt the appliance forward so the rear legs are off the ground. Gently set the appliance back down to allow the rear legs to self adjust.
3. With the appliance in its final position, place a level on top of back part of the washer lid and check it side to side, then check front to back. Screw the front leveling legs up or down to ensure the appliance is resting solid on all four legs (no rocking or the appliance should exist), turn the lock nuts on each leg up toward the base of the unit and snug with a wrench.

note: Keep the leg extension at minimum to prevent excessive vibration. The farther out legs are extended, the more the unit will vibrate.

appliance start-up

The washer and dryer are now ready for use. See the **Owner's Manual** for proper use and care.

